

Hy-Lok RV Series

Relief Valves

Catalog No. H-RV100
Jan. 2002

RV 1 Series

Low Pressure Relief Valve

High Pressure Relief Valve

RV 2 Series

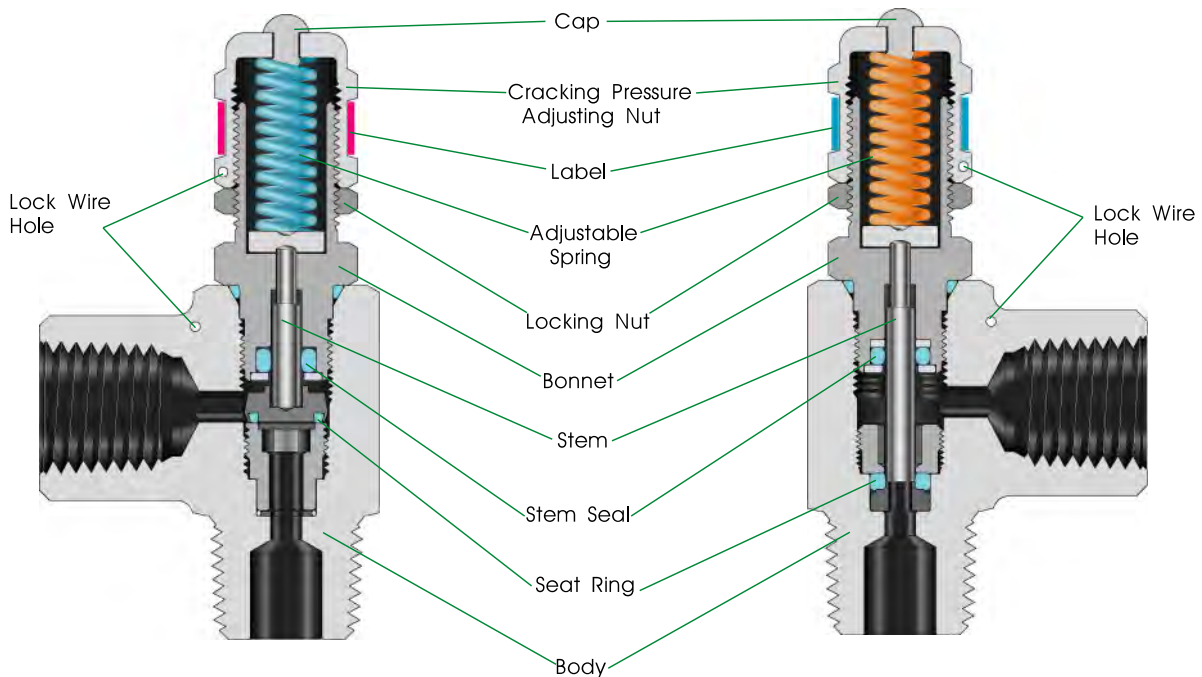

Technical Data

- | | |
|--|--|
| <ul style="list-style-type: none"> • Cracking Pressure Range : 10~250psig to atmosphere • Max.Working Pressure : 300psig • Operating Temperature Range : -10°F~400°F(-23°C~204°C) • Orifice Size : 4.8mm (0.19in) • One Spring adjustable over entire cracking pressure range, blue-color spring standard • Cracking Pressure is affected by the outlet pressure | <ul style="list-style-type: none"> • Cracking Pressure Range : 225~6000psig to atmosphere • Max.Working Pressure : 6000psig • Operating Temperature Range : -10°F~400°F(-23°C~204°C) • Orifice Size : 4.8mm (0.19in) • Various Springs are available as below mentioned. • Cracking Pressure is not affected by the outlet pressure. |
|--|--|

Features

- **Compact body** for installation in small space
- **Cracking pressure** adjustable externally
- **Lock wire capability** to maintain pressure relief setting
- **100% factory tested** crack and reseal performance

Materials of Construction

- Body Material : Stainless Steel 316 (standard)
- Seal : Viton (standard)
- Spring : SS631 (standard)
- Cap : Polypropylene (standard)

Valve Operation and Adjusting Cracking pressure

To increase the cracking pressure, turn the cracking pressure adjusting nut clockwise making the spring more compressed.

RV2 Series Spring and Cracking Pressure

Spring Designator	Cracking Pressure			
	psig	bar	kPa	Color
A	225 - 750	15.5 - 51.5	1550 - 5150	Yellow
B	750 - 1500	51.5 - 103	5150 - 10300	Purple
C	1500 - 2250	103 - 155	10300 - 15500	Orange
D	2250 - 3000	155 - 206	15500 - 20600	Brown
E	3000 - 4000	206 - 275	20600 - 27500	White
F	4000 - 5000	275 - 344	27500 - 34400	Red
G	5000 - 6000	344 - 414	34400 - 41400	Green

CAUTION

RV Series Relief Valves are not "Safety Accessories" as defined in the Pressure Equipment Directive 97/23/EC.



HY-LOK CORPORATION

©1998, 2000, 2002 HY-LOK CORPORATION All rights reserved



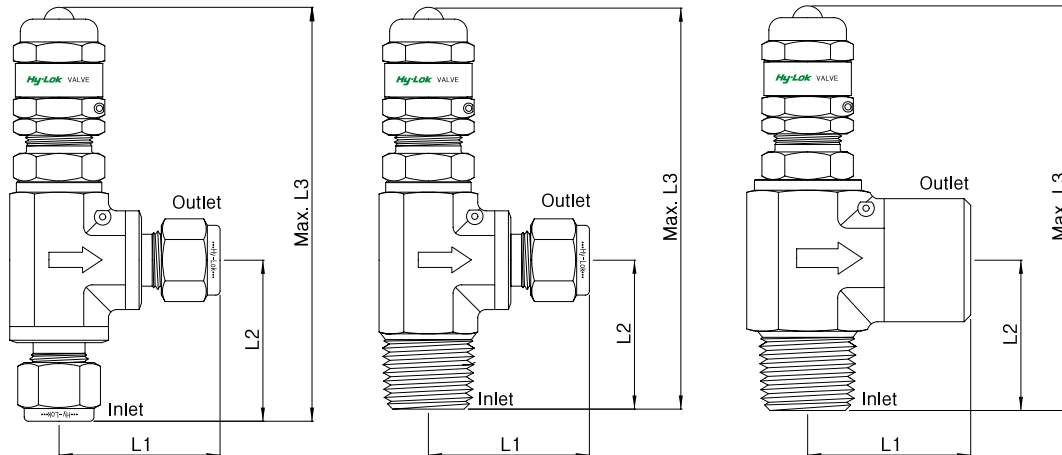

Table of Dimensions

Basic Part No.			Orifice	End Connections		Dimensions		
				Inlet	Outlet	L1	L2	L3
RV1 or RV2	H	-4 T-	4.8	1/4" Hy-Lok	1/4" Hy-Lok	38.7	37.3	104.6
	H	-6M-		6mm Hy-Lok	6mm Hy-Lok			
	H	-8M-		8mm Hy-Lok	8mm Hy-Lok			
	H	-8 T-		1/2" Hy-Lok	1/2" Hy-Lok	46.7	46.7	114.0
	H	-12M-		12mm Hy-Lok	12mm Hy-Lok			
	MH	-8N8T-		1/2" Male NPT	1/2" Hy-Lok	35.7	103.0	
	MH	-8N12M-		1/2" Male NPT	12mm Hy-Lok			
	MF	-4N-		1/4" Male NPT	1/4" Female NPT	30.0	32.2	99.5
	MF	-6N-		3/8" Male NPT	3/8" Female NPT	34.5		
	MF	-8N-		1/2" Male NPT	1/2" Female NPT	38.0		

All dimensions are in millimeters.

Ordering Information

RV2

Series Designator

- RV1 : Low Pressure
- RV2 : High Pressure

MH

End Connection Designator

- H : Both End Hy-Lok Tube Fitting
- MH: Male Pipe Thread & Hy-Lok Tube Fitting
- MF : Male Pipe Thread & Female Pipe Thread

8N

Size Designator

Inlet Outlet

8T

B

Spring / Cracking Pressure Designator*

- A : 225 - 750 psig
- B : 750 - 1500 psig
- C : 1500 - 2250 psig
- D : 2250 - 3000 psig
- E : 3000 - 4000 psig
- F : 4000 - 5000 psig
- G : 5000 - 6000 psig

S316

Body Material Designator

- S316 : 316 Stainless Steel

• NPT (ISO/BSP)

Thread(in.)	1/4	3/8	1/2
Designator	4N(R)	6N(R)	8N(R)

• Tube

Fractional Tube	O.D.(in.)	1/4	3/8	1/2
Designator		4T	6T	8T
Metric Tube	O.D.(mm)	6	8	12
Designator		6M	8M	12M

Note* : No spring / cracking pressure designator is required for RV1 low pressure series valves.

SAFETY in VALVE SELECTION

Proper installation, materials compatibility, operation and maintenance of these valves are the responsibility of the user. The total system design must be taken into consideration to ensure optimal performance and safety.